



US009716813B2

(12) **United States Patent**  
**Han et al.**

(10) **Patent No.:** **US 9,716,813 B2**  
(45) **Date of Patent:** **Jul. 25, 2017**

(54) **AERIAL SURVEY PLANE HAVING COVER FOR PROTECTING LENS OF INFRARED CAMERA FOR AERIAL SURVEY**

(71) Applicant: **KOREA INSTITUTE OF GEOSCIENCE AND MINERAL RESOURCES**, Daejeon (KR)

(72) Inventors: **Jong-Gyu Han**, Daejeon (KR);  
**Ki-Sung Sung**, Incheon (KR);  
**Sung-Soon Lee**, Daejeon (KR);  
**Yeong-Kwang Yeon**, Daejeon (KR);  
**Jeong-Chan Kim**, Daejeon (KR)

(73) Assignee: **Korea Institute of Geoscience and Mineral Resources**, Daejeon (KR)

(\*) Notice: Subject to any disclaimer, the term of this patent is extended or adjusted under 35 U.S.C. 154(b) by 234 days.

(21) Appl. No.: **14/565,252**

(22) Filed: **Dec. 9, 2014**

(65) **Prior Publication Data**  
US 2015/0163381 A1 Jun. 11, 2015

(30) **Foreign Application Priority Data**  
Dec. 10, 2013 (KR) ..... 10-2013-0153233

(51) **Int. Cl.**  
**H04N 7/18** (2006.01)  
**H04N 5/225** (2006.01)  
(Continued)

(52) **U.S. Cl.**  
CPC ..... **H04N 5/2252** (2013.01); **F16M 11/00** (2013.01); **H04N 5/33** (2013.01); **H04N 7/183** (2013.01)

(58) **Field of Classification Search**  
CPC ..... F16M 11/00; H04N 5/2252; H04N 5/33; H04N 7/183

(Continued)

(56) **References Cited**

U.S. PATENT DOCUMENTS

4,835,559 A \* 5/1989 Hattan ..... G03B 19/10  
396/146  
5,426,476 A \* 6/1995 Fussell ..... B64D 47/08  
348/E5.026

(Continued)

FOREIGN PATENT DOCUMENTS

KR 10-0823346 4/2008  
KR 10-2008-0042418 5/2008  
KR 10-2011-0066401 6/2011

OTHER PUBLICATIONS

Xiao-Hong et al, UAV's automatic landing in all weather based on the cooperative object and computer vision, 2012.\*

(Continued)

*Primary Examiner* — Shan Elahi

(74) *Attorney, Agent, or Firm* — Lewis Roca Rothgerber Christie LLP

(57) **ABSTRACT**

An aerial survey plane having a cover for protecting a lens of an infrared camera for an aerial survey according to an exemplary embodiment of the present invention includes: an aerial survey observation window; an aerial survey infrared camera; at least one shock absorbing part to absorb shock applied to the aerial survey infrared camera; at least one support vertically provided on the shock absorbing part; a lifting part to lift and lower the aerial survey infrared camera; a protective cover provided between the aerial survey infrared camera and the bottom surface of the fuselage of the aerial survey plane and having a size to cover the aerial survey observation window; at least one motor to move the protective cover toward any one direction; and a controller to remotely control the opening and the closing of the protective cover.

**12 Claims, 7 Drawing Sheets**

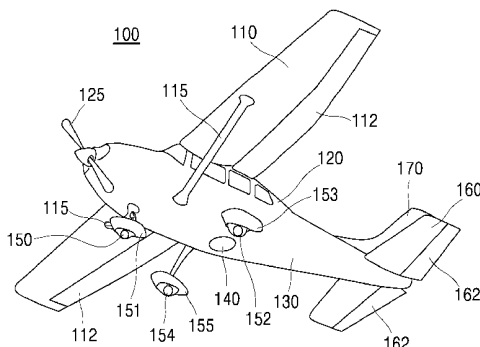

(51) <b>Int. Cl.</b>		2009/0094079 A1 *	4/2009	Linville .....	G01C 21/20
	<i>F16M 11/00</i> (2006.01)				705/5
	<i>H04N 5/33</i> (2006.01)				
(58) <b>Field of Classification Search</b>		2010/0013927 A1 *	1/2010	Nixon .....	G01C 11/06
	USPC .....				348/144
	See application file for complete search history.				
		2012/0069019 A1 *	3/2012	Richards .....	G06T 7/0061
					345/421
		2012/0200703 A1 *	8/2012	Nadir .....	G02B 27/644
					348/144
(56) <b>References Cited</b>		2013/0248656 A1 *	9/2013	Mohamadi .....	H04W 16/26
					244/190
	<b>U.S. PATENT DOCUMENTS</b>	2014/0163772 A1 *	6/2014	Vian .....	G05D 1/0094
					701/2
	6,023,061 A *	2/2000	Bodkin .....	B64D 47/08	
					250/252.1
	6,792,684 B1 *	9/2004	Hyypa .....	G01B 11/00	
					33/1 A
	2007/0025809 A1 *	2/2007	Lee .....	B64F 1/06	
					403/119
	2008/0260237 A1 *	10/2008	Savolainen .....	G06K 9/0063	
					382/154
	2009/0015674 A1 *	1/2009	Alley .....	H04N 7/185	
					348/144

	<b>OTHER PUBLICATIONS</b>	
	Yahyanejad et al, Lens Distortion Correction for Thermal Cameras to Improve Aerial Imaging with Small-Scale UAVs, 2011.*	
	* cited by examiner	

FIG. 1

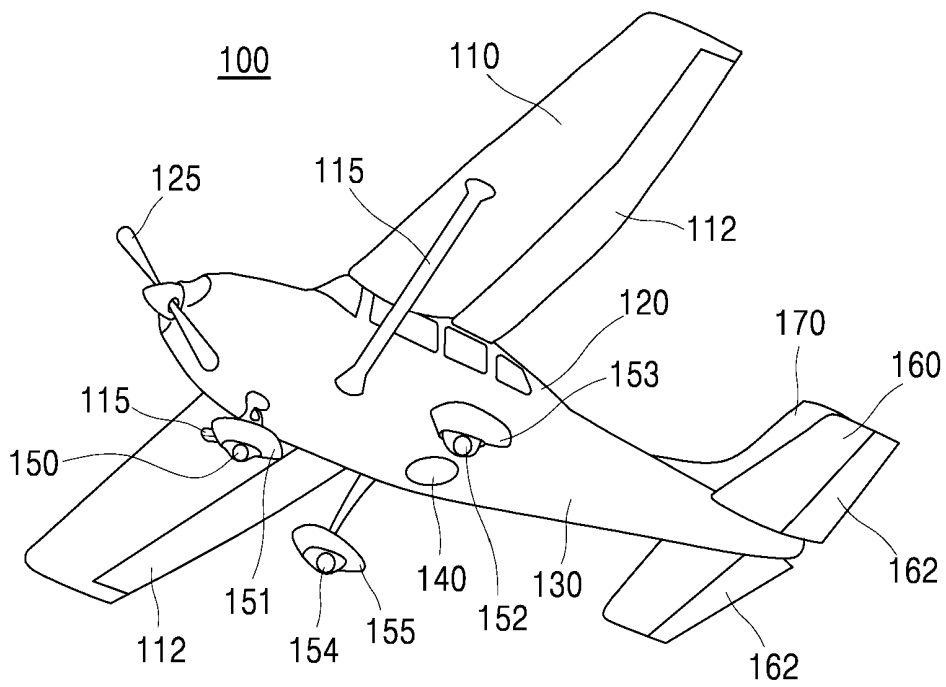

FIG. 2

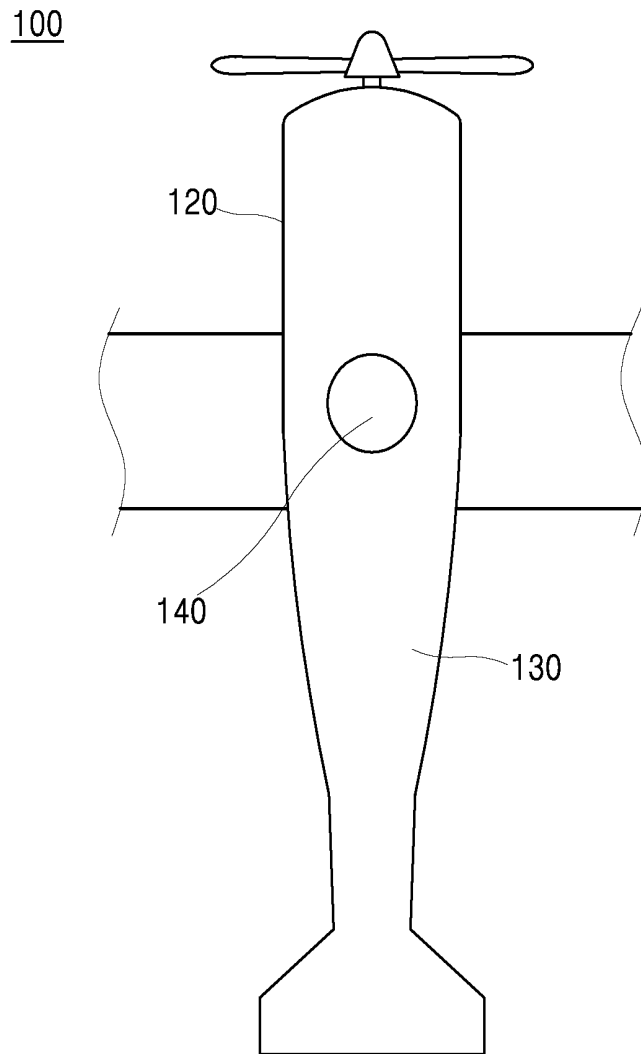

FIG. 3

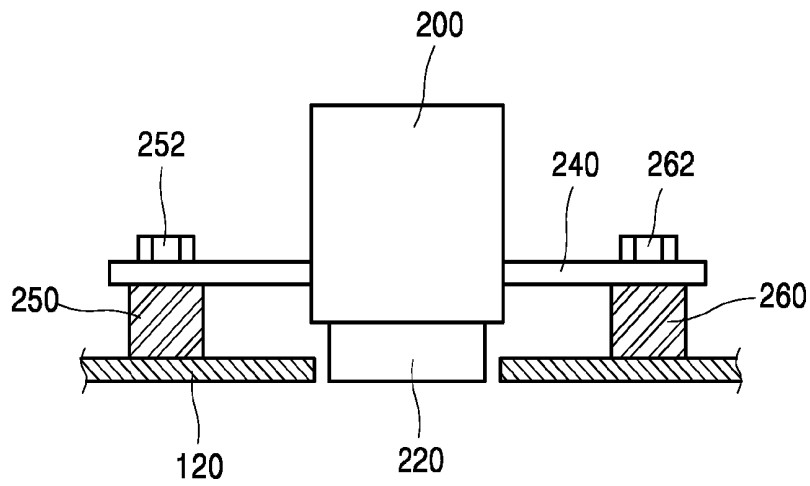

FIG. 4

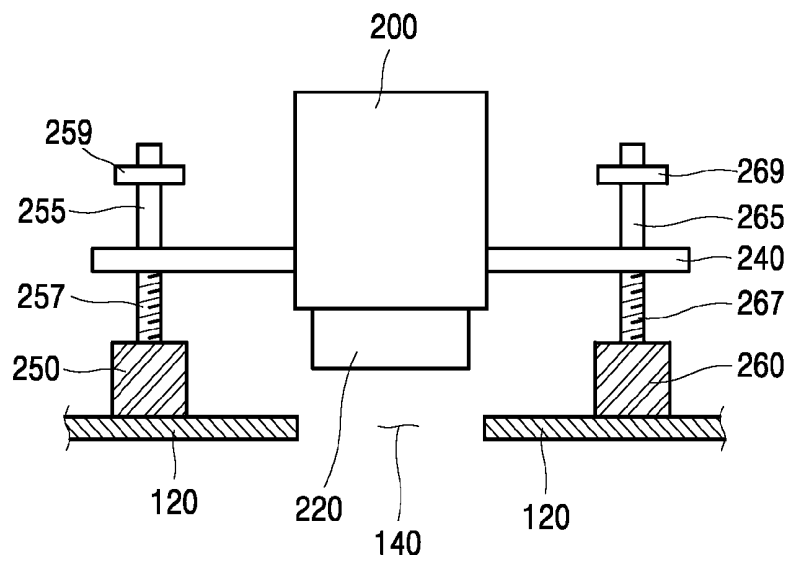

FIG. 5

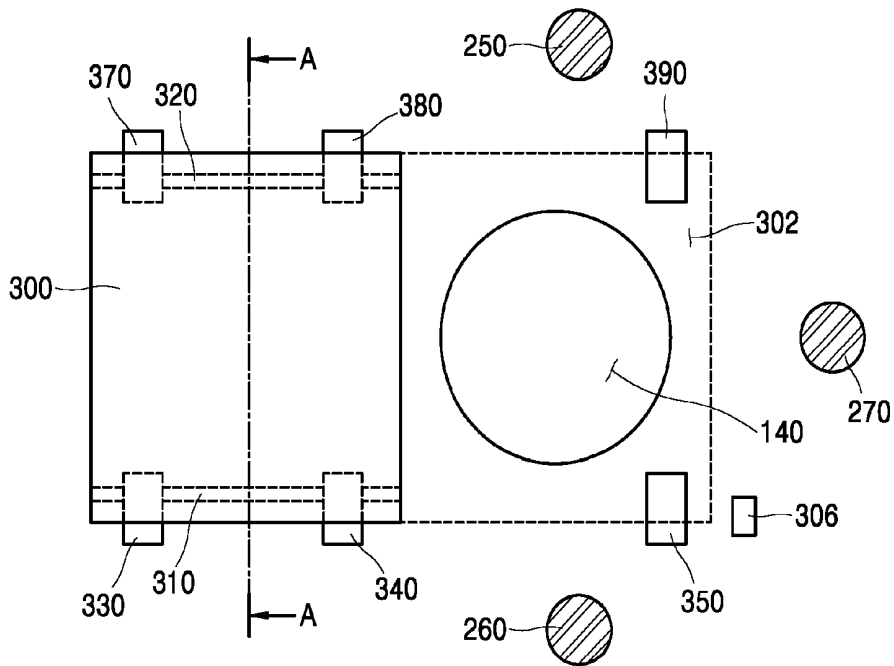

FIG. 6

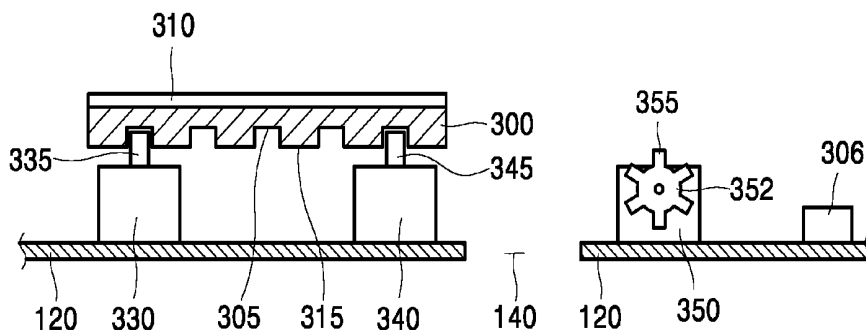

FIG. 7

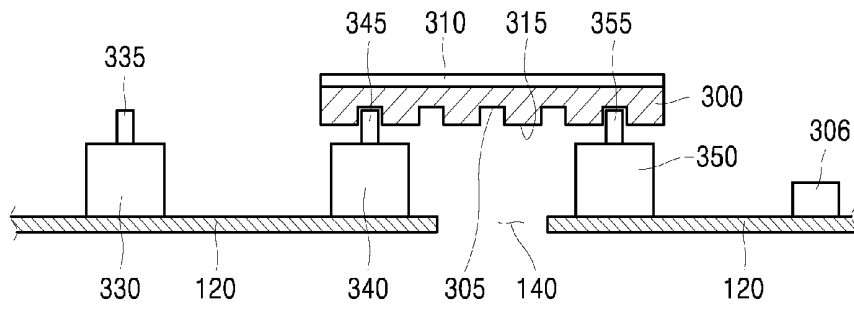

FIG. 8

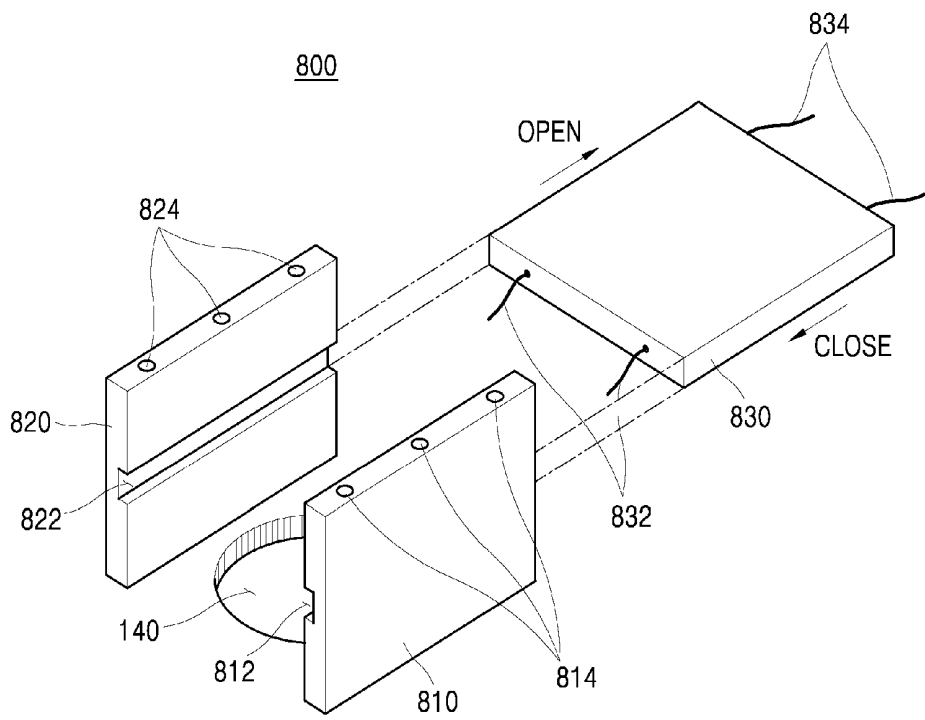

FIG. 9

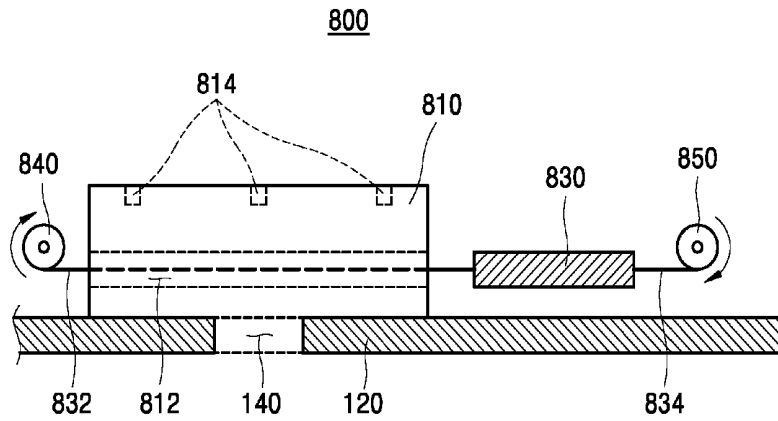

FIG. 10

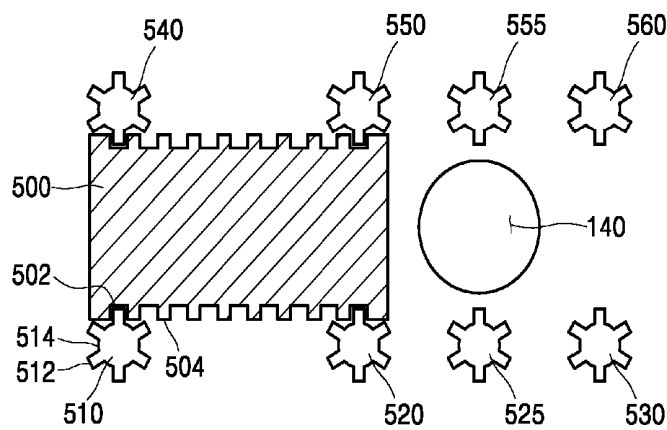
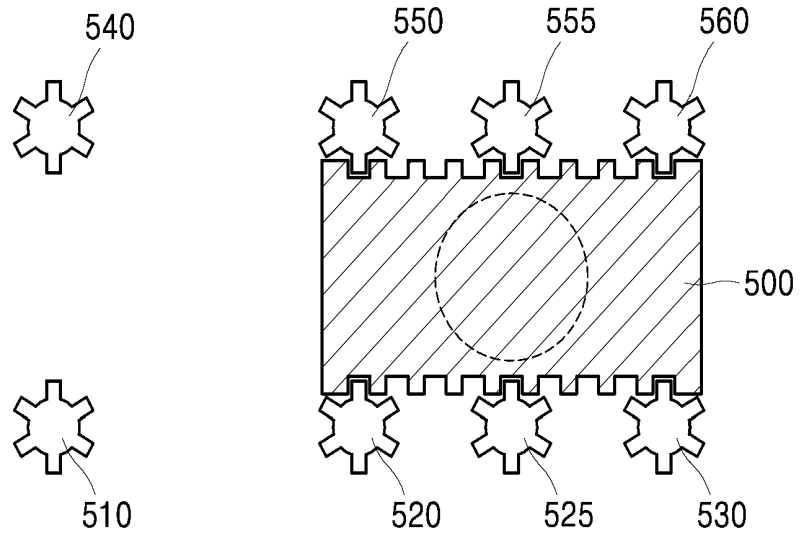



FIG. 11



**AERIAL SURVEY PLANE HAVING COVER  
FOR PROTECTING LENS OF INFRARED  
CAMERA FOR AERIAL SURVEY**

CROSS-REFERENCE TO RELATED  
APPLICATION

This application claims the benefit under 35 U.S.C. §119 of Korean Patent Application No. 10-2013-0153233 filed on Dec. 10, 2013 in the Korean Intellectual Property Office, the entirety of which disclosure is incorporated herein by reference.

BACKGROUND OF THE INVENTION

1) Field of the Invention

The present invention relates to an aerial survey plane having a cover for protecting a lens of an infrared camera for an aerial survey, and more particularly, to an aerial survey plane having a damage protecting cover for preventing a damage to a photographic lens of an infrared camera, which is used for an aerial survey, externally exposed from the aerial survey plane.

2) Background of Related Art

Aerial survey is a method of collecting geomatics or planimetric features of a remote area, and should be distinguished from satellite surveys because of its better resolution.

The aerial survey obtains an image of a target location or a target region with respect to various ranges such as a visible wave range, an infrared wave range and a radio wave range.

To this end, an opening or a protrusion of a predetermined size is formed on a predetermined area of a plane (including a fixed wing and a rotary wing), for example, a part of a fuselage to install various cameras to obtain desired images.

The most basic method of photographing is to externally expose a camera of the aerial survey plane (called "plane") to obtain the desired image, and because this method is very vulnerable to unpredictable situations such as vibrations or sudden shaking of the plane, this method is only used when the aerial survey is performed as a hobby.

For other methods, various supporters are installed on an external surface of the plane and the aerial survey camera is fixed to the supporter, but because of the variation of the center of gravity of the plane due to the uneven distribution of weight, controlling the plane may be more difficult.

Therefore, for a stable aerial survey, the aerial survey camera is installed at a center of a bottom part of the fuselage of the corresponding plane.

For a smooth operation of the aerial survey camera, an opening is preferably formed in the bottom part of the corresponding plane.

In addition, the lens unit of the aerial survey camera is preferably installed while facing the ground surface or the water surface through the opening.

In this case, because the aerial survey is performed at a high altitude instead of a low altitude to increase the efficiency of surveying a large area in a short period of time, a device for protecting the camera from cold air or sudden foreign materials is required when moving from the low altitude to the high altitude or vice versa.

In this case, in general, because the weather at low altitudes is bad, an outer surface, especially a lens surface of the aerial survey camera may be damaged because of the bad

weather when ascending from the low altitude to the high altitude or descending from the high altitude to the low altitude.

In addition, the aerial survey is normally performed by flying back and forth along a predetermined track as if plowing in a farm, and because the turning radius is considerably large, the amount of time that the camera is exposed to the external atmosphere is also considerably long.

As described, the outer surface of the aerial survey camera may be damaged due to a locally bad weather even when the camera is exposed while the aerial survey plane is rotating.

Further, the outer surface of the aerial survey camera may be damaged by foreign materials such a sand from a runway when the plane takes-off or lands for the aerial survey. Therefore, a device for protecting the outer surface of the aerial survey camera of the plane is required.

For reference, although the aerial survey camera used in the aerial survey plane of the present invention employs an infrared camera, various cameras other than the infrared camera can also be used for the aerial survey, and aerial surveys may use the camera to photograph the ultraviolet wave range or a conventional optical camera to photograph the visible wave range. In this case, for example, a surface of the lens of an image collecting unit of the aerial survey camera is handled with caution such that scratches do not occur.

Hereinafter, a method of using the aerial survey infrared camera in the aerial survey plane according to the related art will be briefly described with reference to FIG. 1 to FIG. 3.

FIG. 1 is a bottom perspective view illustrating an example of the aerial survey plane having the aerial survey infrared camera, FIG. 2 is a schematic bottom view illustrating a bottom structure of the aerial survey plane illustrated in FIG. 1, and FIG. 3 is a side sectional view illustrating the aerial survey infrared camera installed in the aerial survey plane according to the related art.

According to FIG. 1, an aerial survey plane 100 of the related art mainly includes a main wing 110, a fuselage 120, a horizontal tail wing 160 and a vertical tail wing 170. An auxiliary support 115 may be further formed between the main wing 110 and the fuselage 120 to reinforce strength.

In addition, a flap, an aileron 112 and an elevator 162 to assist a flight may be further formed on the main wing 110 and the tail wing 160.

The aerial survey plane 100 essentially further includes a propeller 125 to provide power during flight, but a method of providing power during flight is not limited to the propeller 125.

On the bottom surface 130, which constitutes a lower surface of the fuselage 120, landing gears 150, 152 and 154 are formed to help the landing and the take-off of the aerial survey plane 100. On the landing gears 150, 152 and 154, as described above, landing gear covers 151, 153 and 155 may be further provided, respectively, to actively prevent scattering of various fragments from occurring during the landing and the take-off of the aerial survey plane 100.

In this case, damage to the lens surface of the aerial survey infrared camera, which is installed in the aerial survey plane 100, may be actively prevented.

In addition, as illustrated in FIG. 2, an aerial survey observation window 140, on which the aerial survey infrared camera (not illustrated) is mounted, having a predetermined size is provided on the bottom surface 130 of the aerial survey plane 100.

The size of the aerial survey observation window 140 is standardized with a large diameter of 19 inches (48.26 cm)

and a small diameter of 8 inches (20.32 cm). Therefore, there may be two types of covers to open and cover the aerial survey observation window **140**.

Meanwhile, the aerial survey infrared camera (not illustrated) faces the ground surface or the water surface in the aerial survey observation window **140**.

Even though the present invention describes that the aerial survey infrared camera (not illustrated) faces the ground surface or the water surface, the present invention is not limited thereto and the aerial survey infrared camera (not illustrated) may be disposed while facing an opposite direction of the ground surface or the water surface.

Meanwhile, according to FIG. 3, the aerial survey infrared camera **200** may be installed on a part of the fuselage **120**, that is an opening formed on the bottom surface of the aerial survey plane **100**.

In FIG. 3, a reference numeral **220** may be a lens externally exposed from the aerial survey infrared camera **200**.

In addition, the aerial survey infrared camera **200** may be fixedly installed on the fuselage **120** through a supporting plate **240**. In this case, shock absorbing units **250** and **260** having elasticity are preferably installed between the supporting plate **240** and the fuselage **120**.

The shock absorbing units **250** and **260** preferably use a rubber material for elasticity, and more preferably use a synthetic rubber material by taking severe environments into consideration.

In addition, the supporting plate **240** and the shock absorbing units **250** and **260** are preferably fixed by bolts **252** and **262**.

As illustrated in FIG. 3, because the lens **220** of the aerial survey infrared camera **200** is externally exposed, as described above, the outer surface of the lens may be damaged from various foreign materials.

As related arts, there is Korean Unexamined Patent Publication No. 10-2008-0042418 (Published on May 15, 2008, Apparatus for protecting camera of heavy machinery). The publication discloses a configuration for preventing a rear observation camera of the heavy machinery from damage by various fragments.

#### SUMMARY OF THE INVENTION

Therefore, the present invention has been made to solve the described problems, and an object of the present invention is to provide an aerial survey plane having a cover for protecting a lens of an infrared camera for an aerial survey, which may protect an external surface of the camera exposed to an exterior of the aerial survey plane from various external impacts.

In addition, another object of the present invention is to provide a protective cover which may protect the infrared camera for the aerial survey from thermal impact caused by external temperatures.

Objects of the present invention may not be limited to the above objects, and other objects will be clearly understandable to those of ordinary skill in the art from the disclosures provided below.

To solve the object described above, an aerial survey plane having a cover for protecting a lens of an infrared camera for an aerial survey according to an exemplary embodiment of the present invention includes: an aerial survey observation window provided on a bottom surface of a fuselage of an aerial survey plane and having a predetermined size; an aerial survey infrared camera disposed at the aerial survey observation window and facing a ground

surface or a water surface; at least one shock absorbing part disposed on a lower part of the aerial survey infrared camera to absorb shock applied to the aerial survey infrared camera from the aerial survey plane; at least one support vertically provided on the shock absorbing part to support the aerial survey infrared camera while surrounding the aerial survey infrared camera; a lifting part to lift up and down the aerial survey infrared camera; a protective cover provided between the aerial survey infrared camera and the bottom surface of the fuselage of the aerial survey plane and having a size to cover the aerial survey observation window to close the aerial survey observation window before the aerial survey plane starts an aerial survey; at least one motor disposed on at least one side surface of the protective cover to move the protective cover in a predetermined direction so that the aerial survey observation window is opened to start the aerial survey and the aerial survey observation window is closed to protect the lens of the aerial survey infrared camera; and a controller to remotely control the opening and the closing of the protective cover.

In this case, the lifting part is preferably integrally formed with the support and has at least one of a screw type, a hydraulic type and an electronic type.

In addition, to reduce control time, the lifting part may be a lever type capable of lifting up and down the aerial survey infrared camera by one manipulation.

Further, the protective cover may include a hard plate.

In addition, the motor preferably includes a rotating gear part including a protruding part to move the protective cover in one direction, and the protective cover preferably includes a groove part having a predetermined pitch to engage with the protruding part of the gear unit.

Further, the groove part preferably includes at least one row of grooves formed on an upper part or a lower part of the protective cover.

Alternately, the groove part may be formed on at least one of side surfaces of the protective cover.

To solve the object described above, an aerial survey plane having a cover for protecting a lens of an infrared camera for an aerial survey according to another exemplary embodiment of the present invention includes: an aerial survey observation window provided on a bottom surface of a fuselage of an aerial survey plane and having a predetermined size; an aerial survey infrared camera disposed at the aerial survey observation window and facing a ground surface or a water surface; guide blocks disposed at a lower part of the aerial survey infrared camera interposing the aerial survey observation window therebetween and comprising a coupling part on an upper end thereof to be coupled to the aerial survey infrared camera; a guide groove formed in a longitudinal direction on side surfaces of the guide blocks facing each other; a protective cover inserted into the guide groove to move back and forth in the longitudinal direction; a wire fixedly installed on at least one of side ends of the protective cover; a first motor and a second motor disposed on both sides of the guide block, respectively, to wind the wire fixedly installed on the side end of the protective cover; and a controller to remotely control the opening and the closing of the protective cover.

In this case, an upper part of the guide block is preferably fixed to the aerial survey infrared camera through the coupling part and a lower part of the guide block more preferably includes a shock absorbing part to absorb a shock applied thereto.

In addition, preferably, the first motor winds the wire while the second motor applies a predetermined amount of tension to the wire fixedly coupled to the protective cover

and the second motor to suppress a fluctuation of the protective cover when closing the aerial survey observation window, and the second motor winds the wire while the first motor applies a predetermined amount of tension to the wire fixedly coupled to the protective cover and the first motor to suppress the fluctuation of the protective cover when opening the protective cover.

Further, preferably, the protective cover is provided between the aerial survey infrared camera and the bottom surface of the fuselage of the aerial survey plane and has a size to cover the aerial survey observation window to close the aerial survey observation window before the aerial survey plane starts an aerial survey.

Details of other embodiments are included in the detailed description and the accompanying drawings.

Advantages and features of the present invention, and method for achieving thereof will be apparent with reference to the examples that follow. But, it should be understood that the present invention is not limited to the following embodiments and may be embodied in different ways, and that the embodiments are given to provide complete disclosure of the invention and to provide thorough understanding of the invention to those skilled in the art, and the scope of the invention is limited only by the accompanying claims and equivalents thereof.

In the following description, the same reference numerals will be assigned to the same elements, and sizes, positions and relationships of each element of the present invention may be exaggerated for clarity of description. In addition, when describing embodiments of the present invention, detailed descriptions of well-known functions and structures incorporated herein may be omitted when they make the subject matter of the present invention unclear.

According to an exemplary embodiment of the present invention, an externally exposed surface of an aerial survey infrared camera, which is externally exposed from the aerial survey plane, may be effectively protected from foreign materials or fragments by a cover for protecting a lens of an infrared camera for an aerial survey.

In addition, according to an exemplary embodiment related to an aerial survey plane having a cover for protecting a lens of an infrared camera for an aerial survey, a lens of the aerial survey infrared camera may be effectively protected from an external temperature of the aerial survey plane.

#### BRIEF DESCRIPTION OF THE DRAWINGS

FIG. 1 is a bottom perspective view illustrating an example of an aerial survey plane having an aerial survey infrared camera.

FIG. 2 is a schematic bottom view illustrating a bottom structure of the aerial survey plane illustrated in FIG. 1.

FIG. 3 is a side sectional view illustrating the aerial survey infrared camera installed in the aerial survey plane.

FIG. 4 is a side sectional view illustrating the aerial survey infrared camera illustrated in FIG. 3 having an altered height to describe an exemplary embodiment of the present invention.

FIG. 5 is a plan view illustrating a hard plate type protective cover which is open to expose an aerial survey observation window according to an exemplary embodiment of the present invention.

FIG. 6 is a first side sectional view illustrating a protective cover which is open to expose the aerial survey observation window according to an exemplary embodiment of the present invention.

FIG. 7 is a second side sectional view illustrating a protective cover which is closed to cover the aerial survey observation window according to an exemplary embodiment of the present invention.

FIG. 8 is a perspective view illustrating an open state of an aerial survey observation window in the aerial survey plane having the cover for protecting the aerial survey infrared camera according to another exemplary embodiment of the present invention.

FIG. 9 is a side sectional view of the protective cover of the aerial survey plane having the cover for protecting the aerial survey infrared camera according to another exemplary embodiment of the present invention illustrated in FIG. 8.

FIG. 10 is a plan view illustrating the hard plate type protective cover which is open to expose the aerial survey observation window according to another exemplary embodiment of the present invention illustrated in FIG. 5.

FIG. 11 is a plan view illustrating the protective cover which is closed to cover the aerial survey observation window according to another embodiment of the present invention illustrated in FIG. 5.

#### DETAILED DESCRIPTION OF THE INVENTION

Hereinafter, an embodiment of the present invention is described in detail with reference to the accompanying drawings.

FIG. 4 is a side sectional view illustrating an aerial survey infrared camera (hereinafter, referred to as "aerial survey camera") illustrated in FIG. 3 having an altered height to describe an exemplary embodiment of the present invention.

According to FIG. 4, the height of an aerial survey camera 200 fixedly installed in an aerial survey plane 100, and in this case, the aerial survey camera 200 is lifted up and down by lifting parts 257 and 267 formed on supports 255 and 265, respectively, which are vertically inserted on a supporting plate 240. In FIG. 4, the supports 255 and 265 are preferably formed vertical to shock absorbing units 250 and 260.

In FIG. 4, screw type lifting parts 257 and 267 are illustrated, and to move the aerial survey camera 200 up and down by the lifting parts 257 and 267, for example, control handles 259 and 269 may be rotated.

The lifting parts 257 and 267 illustrated in FIG. 4 may be formed as a hydraulic type or an electronic type instead of the screw type.

The hydraulic type or the electronic type may be remotely controlled through a controller (not illustrated).

When remotely controlling the lifting parts 257 and 267, as described above, passengers of the aerial survey plane can be protected from an outside cold, which may be tens of degree below zero at high altitudes.

A hydraulic actuator may be installed in the case of the hydraulic type, a linear motor or a linear actuator may be installed in the case of the electronic type.

In addition, the remote control may be performed by a wired or a wireless scheme. The lifting parts 257 and 267 formed on the supports 255 and 265 may vertically move up and down by the remote control in so that the aerial survey camera 200 may be moved up and down.

When the aerial survey camera 200 is moved up, an aerial survey observation window 140 is opened, and a cover (not illustrated, refer to FIG. 5) for protecting a lens of an aerial survey infrared camera according to an exemplary embodiment of the present invention may protect a lens 220 of the aerial survey plane 200 from external foreign materials.

That is, the aerial survey camera **200** performs an aerial survey in a lowered position as illustrated in FIG. **3** during the aerial survey, and when situations of concerns of external foreign materials arise such as during landing and take-off of the aerial survey plane, the lens protecting cover is moved to close the aerial survey observation window **140** so that the damage to a surface of the lens **220** of the aerial survey camera **200** is maximally prevented.

In this case, the lifting parts **257** and **267** may be formed in a lever type, in which the aerial survey camera is moved up or down by one manipulation thus reducing control time.

In the case of the screw type, taking into consideration that the time to rotate the control handles **259** and **269** formed on the lifting parts **257** and **267** takes a very long time, the advantage of time saving by the lever type is obvious.

In addition, the lever type is relatively free from failures or errors that may occur in the hydraulic or the electronic type.

Meanwhile, the lever type may preferably have a configuration of a lever installed on a lower part of the support plate **240** as in FIG. **4**. When a lever type is used, the support plate **240** is preferably configured in such a manner that the camera does not fall due to the weight of the camera or an impact when the support plate **240** is moved up for safety reasons.

And at the same time, for a swift aerial survey, the support plate **240** is more preferably configured in such a manner that the support plate **240** moves down slowly so that, for example, impact to the aerial survey camera **200** by striking the shock absorbing part **250** and **260** with a powerful force may be avoided.

In addition, the lever may be installed on at least one position among a left side, a right side, a rear or a front of the drawing in FIG. **4**, but when the weight of the aerial survey camera **200** is very heavy, the camera is preferably supported by levers at both sides of the camera.

In this case, a typical lever configuration may be used to move the support plate **240**, on which the aerial survey camera **200** is fixed, and a detailed configuration is not described in detail.

FIG. **5** is a plan view illustrating hard plate type protective cover which is open to expose an aerial survey observation window according to an exemplary embodiment of the present invention.

According to FIG. **5**, the shock absorbing parts **250**, **260** and **270** having elasticity are provided at three positions. In a position where the shock absorbing parts **250**, **260** and **270** are not provided, the hard plate type protective cover **300** is disposed to move left and right with reference to the drawing so that the aerial survey observation window **140** is exposed.

Preferably, the protective cover **300** is provided between the lens **220** of the aerial survey camera **200** and a bottom surface, which is a lower surface of the fuselage of the aerial survey plane **100** and has a size that may sufficiently cover the aerial survey observation window **140**. In addition, the protective cover **300** more preferably closes the aerial survey observation window **140** before the aerial survey plane **100** starts the aerial survey.

The protective cover **300** is preferably formed in a hard plate having a predetermined thickness, and is more preferably formed in a metal plate to sufficiently protect the camera from large sized fragments.

In addition, the protective cover **300** is preferably adhered to a surface of the fuselage **120**, if possible, to minimize the size of the opening of the aerial survey observation window **140**.

In this case, the passengers can be more effectively protected from external thermal shock.

Not only the protective cover **300**, but all protective covers described in the present invention are preferably adhered to the fuselage **120**.

In addition, to assist the left and right movements of the protective cover **300**, at least one motor **330**, **340**, **370** and **380** may be installed to each edge of a lower part of the protective cover **300**.

In FIG. **5**, reference numerals **350** and **390** indicates motors, which are engaged with a rightmost end of the moving protective cover **300** when the protective cover **300** starts moving right.

The protective cover **300** moves from left to right, and to guide this movement more smoothly, at least one guide groove **310** and **320** may be provided on an upper surface of the protective cover **300** in parallel to the movement direction of the protective cover **300**.

A protrusion (not illustrated) may be provided on a lower part of the support plate **240** corresponding to the guide grooves **310** and **320**.

A stable left and right movement of the protective cover **300** may be assured by the configuration of the guide grooves **310** and **320** and the protrusion.

When the protective cover **300** starts moving, in addition to the guidance by the guide grooves **310** and **320**, another motor (not illustrated, for example, an auxiliary motor **525** and/or **555** of FIG. **10** and FIG. **11**) may be further provided between the motors **340** and **350** and the motors **380** and **390**.

In this case, a more stable movement of the protective cover **300** may be assured.

In FIG. **4**, a reference number **306** may be a controller to control the opening and closing of the protective cover **300**.

In this case, the controller **306**, as described above, may be configured to be remotely controllable to protect the passengers of the aerial survey plane from the external cold. The remote control may be operated by a wired or wireless communication, and in any case, is preferably doubly backed up for reliability. This is because a cost required for landing is enormous when a failure occurs after the aerial survey is started.

Meanwhile, to prevent an excessive left and right movement of the protective cover **300** and damage or dislocation from the excessive movement, the motors **330**, **340**, **370** and **380** may further include an apparatus for measuring a travel distance, for example a rotary encoder.

Alternately, a contact type and/or an optical type sensor (not illustrated), which may detect a completion of the movement of the protective cover **300**, may be further provided at a leftmost side and/or a rightmost side of the protective cover **300** and/or on a movement path of the protective cover **300**.

The movement of the protective cover **300** and the opening and closing of the aerial survey observation window **140** are described in more detail with reference to FIG. **6** and FIG. **7**.

FIG. **6** is a first side sectional view illustrating the protective cover which is open to expose the aerial survey observation window according to an exemplary embodiment of the present invention and FIG. **7** is a second side sectional view illustrating the protective cover which is closed to cover the aerial survey observation window according to an exemplary embodiment of the present invention.

Various reference numerals in FIG. **6** and FIG. **7** are same as the reference numerals in FIG. **5**, so descriptions of the same reference numerals are omitted.

In FIG. 6, protrusions **335** and **345** are formed on the motors **330** and **340** to engage with a gear part having a plurality of groove parts **305** and protrusion parts **315** in a constant interval on the protective cover **300**.

The protrusions **225** and **245** may be used when moving the protective cover **300** to one direction.

Along with the protrusion parts **335** and **345**, groove parts are also formed on the motors **330** and **340** but are not illustrated in the drawing.

The reason for adopting a gear part is because of the adverse condition inflicted to the aerial survey plane **100** while flying.

That is, not only a force pushing the aerial survey plane **100** backward by the movement of the aerial survey plane **100**, but also a centrifugal force due to a turning of the plane, a vibration of the plane and various external disturbances may be inflicted to the aerial survey plane **100** while flying.

In addition, the plurality of grooves **305** and protrusions **315** formed on the protective cover **300**, as illustrated in FIG. 5, are preferably formed in parallel to the guide grooves **310** and **320**. In this case, the groove parts **305** and the protrusion parts **315** may be formed on one side surface of the protective cover **300**, and more preferably formed on both sides for safety.

The protective cover **300** preferably includes groove parts **305** provided on at least one side surface of the protective cover **300** in a constant interval to engage with the protrusion part of the gear part.

In addition, the groove parts **305** of the protective cover **300** may have at least one row of the grooves formed on an upper part or a lower part of the protective cover **300**.

When the groove parts **305** have at least one row, the protective cover **300** may move more safely.

Hereinafter, an interior structure of the motor **350** is described with reference to FIG. 6.

The motor **350** includes a rotating gear part **352** inside and one protrusion part **355** among a plurality of protrusion parts formed on the gear part **352** protrudes through to the outside of the motor **350**.

The protrusion part **355** may engage with the groove parts **305** formed on the protective cover **300** when the protective cover **300** is moved to the right side of the drawing. Because of the engagement, a stable movement to the right side of the protective cover **300** may be assured.

An overall configuration of FIG. 7 is same as FIG. 6, and illustrates a closed state of the aerial survey observation window **140** after the protective cover **300** completed moving to the right side as in FIG. 6 so additional description is omitted.

The configuration of the gear part having the groove parts **305** and the protrusion parts **315** is used to move the protective cover **300** left and right in FIG. 5 to FIG. 7, but alternatively, a configuration using a chain may be used.

In this case, the chain may engage the groove parts **305** and the protrusion parts **315** formed on the protective cover **300** while passing through insides of the motors **330**, **340** and **350** to form a caterpillar type configuration.

Hereinafter, the aerial survey plane having a cover for protecting a lens of infrared camera for an aerial survey according to another exemplary embodiment of the present invention is described with reference to FIG. 8 and FIG. 9.

FIG. 8 is a perspective view illustrating the open state of an aerial survey observation window in the aerial survey plane having a cover for protecting a lens of an infrared camera for an aerial survey according to another exemplary embodiment of the present invention, and FIG. 9 is a side sectional view of the protective cover of the aerial survey

plane having a cover for protecting a lens of an infrared camera for an aerial survey according to another exemplary embodiment of the present invention illustrated in FIG. 8.

As illustrated in FIG. 8, the aerial survey plane **800** having a cover **830** for protecting a lens of an infrared camera (not illustrated) for an aerial survey according to another exemplary embodiment of the present invention includes the aerial survey observation window **140** opened in a predetermined size on the bottom surface of the fuselage **120** of an aerial survey plane **800**.

In addition, the aerial survey infrared camera (not illustrated) is disposed on the upper part of the aerial survey observation window **140** and faces the ground surface or the water surface.

Guide blocks **810** and **820** are provided on the lower part of the aerial survey infrared camera (not illustrated), interposing the aerial survey observation window **140** therebetween and includes coupling parts **814** and **824** to be coupled to the infrared camera (not illustrated) for the aerial survey.

Three coupling parts **814** and **824** are illustrated for the coupling part in the drawing, but the number of coupling parts may increase or decrease according to needs.

Guide grooves **812** and **822** may be formed on side surfaces of the guide blocks **810** and **820** facing each other in a longitudinal direction.

In addition, the protective cover **830** may be inserted in the guide grooves **812** and **822** to move back and forth in the longitudinal direction.

In this case, preferably, the protective cover **830** is provided between the aerial survey infrared camera and the bottom surface of the fuselage **120** of the aerial survey plane **800** and has the size that may cover the aerial survey observation window **140**.

In addition, the protective cover **830** preferably closes the aerial survey observation window **140** before the aerial survey plane **800** starts the aerial survey.

Meanwhile, wires **832** and **842** are fixed to at least one side end of the protective cover.

In this case, a first motor **840** and a second motor **850** may be provided to wind the wires **832** and **842**, which are longitudinally disposed at both sides of the guide blocks **810** and **820** and fixed to the side end of the protective cover **830**.

In addition, a controller (not illustrated) is preferably further included to remotely control the opening and closing of the protective cover **830**.

A thickness of the protective cover **830** is preferably approximately same as a thickness of the guide grooves **812** and **822** formed on the guide blocks **810** and **820**.

In addition, the aerial survey infrared camera (not illustrated) may be fixed through the coupling parts **814** and **824** on the guide blocks **810** and **820**.

In this case, the coupling method is preferably a screw type coupling though a bolt and a nut for a simple coupling, but may be fixedly coupled by welding.

In this case, a shock absorbing part (not illustrated) may be further included to absorb an impact applied to a lower part of the guide blocks **810** and **820**.

In addition, the shock absorbing part in this case preferably has a configuration similar to the shock absorbing parts **250** and **260** illustrated in FIG. 3.

Hereinafter, operations of the first motor **840** and the second motor **850** are briefly described.

When closing the aerial survey observation window **140** by the protective cover **830**, the controller is driven so that the first motor **840** winds the wire **832**.

In this case, the winding direction of the wire may be in a counter clockwise direction as illustrated in FIG. 9.

At the same time, the second motor **850** preferably applies a predetermined tension to the wire **834** fixedly coupled to the protective cover **830** and the second motor **850**.

A fluctuation of the protective cover **830** may be suppressed by the tension.

Whereas, when opening the protective cover **830**, the controller is driven so that the second motor **850** winds the wire **834**.

In this case, the winding direction of the wire **834** may be in a clockwise direction instead of the counter clockwise direction illustrated in FIG. **9**.

At the same time, the first motor **840** preferably applies a predetermined tension to the wire **832** fixedly coupled to the protective cover **830** and the first motor **840**.

A fluctuation of the protective cover **830** may be actively suppressed by the tension.

Instead of the embodiments illustrated in FIG. **8** and FIG. **9**, the gear part illustrated in FIG. **5** to FIG. **7** may be implemented at an inner part of the guide grooves instead the protective cover **830** being inserted in the guide grooves **812** and **822** to control the movement by the controller through the wires **832** and **842**.

In this case, because complicated position control such as winding the wires **832** and **842** is not performed and the travel distance of the gear part may be easily determined, the position of the protective cover **830** may be accurately controlled.

In this case, a sensor unit (not illustrated) to detect an excessive winding of the protective cover **830** may be further provided.

The sensor unit may detect a travel distance of the wires **832** and/or **842** by measuring a number of rotations of the first motor **840** and the second motor **850**.

Alternatively, the sensor unit may be a displacement meter to measure a relative displacement between the guide blocks **810** and/or **820** and the protective cover **830**.

Further, the sensor unit may be a contact type or a non-contact type detection sensor to detect if the protective cover **830** is at a predetermined position.

In short, it is sufficient for the sensor unit if the sensor unit is able to control the opening and closing of the protective cover so that the protective cover **830** sufficiently closes and opens the aerial survey observation window **140**.

Hereinafter, another embodiment of an exemplary embodiment of the present invention illustrated in FIG. **5** is described.

FIG. **10** is a plan view illustrating the opened hard plate type protective cover to expose the aerial survey observation window according to another exemplary embodiment of the present invention illustrated in FIG. **5** and FIG. **11** is a plan view illustrating the closed protective cover to cover the aerial survey observation window according to another embodiment of the present invention illustrated in FIG. **5**.

FIG. **10** and FIG. **11**, which are different from FIG. **5** in that the protective cover **500** moves in parallel to the fuselage **120** instead of moving vertical to the fuselage **120**.

The elements such as a protective cover **500**, groove parts **502** and protrusion parts **504** of the protective cover **500**, motors **510**, **520**, **530**, **540**, **550** and **560** and groove parts **512** and protrusion parts **514** of the motor **510** corresponds with the elements of FIG. **5** to FIG. **7**.

The elements of FIG. **5** to FIG. **7** are basically vertically installed and vertically operated, and the elements of FIG. **10** to FIG. **11** are basically transversely installed and transversely operated.

In addition, the guide grooves **310** and **320** may be also provided in FIG. **10** and FIG. **11**.

FIG. **10** illustrates the opened aerial survey observation window **140**, and in this case, typically, the groove parts **512** and the protrusion parts **514** of the motor **510** engage and rotate with the groove parts **502** and the protrusion parts **504** of the protective cover **500** so that the protective cover moves from left to right in the drawing.

The groove parts **502** and the protrusion parts **504** may be formed on at least one side surface with respect to the travel direction of the protective cover **500**.

The movement of the protective cover **500** in FIG. **10** and FIG. **11** is identical to the movement of the protective cover in FIG. **5** to FIG. **7**, so the description of the movement of the protective cover **500** is omitted.

The protective covers **300**, **400** and **500** are preferably formed to make contact with the fuselage **120** instead of the illustrations in each drawing.

In addition, the protective covers **300**, **400** and **500** are preferably opened and closed from the tail of the plane to the front of the plane, other than from the front of the plane to the tail of the plane, by taking into consideration the flight characteristic of the aerial survey plane **100**.

If the aerial survey plane **100** is not a fixed wing plane as illustrated, the opening and closing direction of the protective covers **300**, **400** and **500** may be relatively freely set.

In addition, the opening and closing of the protective covers **300**, **400** and **500** may be remotely controlled, but may be automatically opened and closed without human control by using a geographical information assisting system such as a GPS when entering a predetermined track or altitude considering the characteristic of the aerial survey.

In addition, when using the GPS, the protective covers **300**, **400** and **500** may be automatically opened when arriving at an aerial survey area and the protective covers **300**, **400** and **500** may be automatically closed when the aerial survey is ended, that is deviating from the corresponding area.

In this case, tiredness from manually controlling the protective covers **300**, **400** and **500** may be alleviated because a person does not need to open and close the protective covers **300**, **400** and **500** by hand.

While the present invention has been particularly shown and described with reference to various embodiments thereof, it should not be interpreted in any way to limit the scope of the present invention, and it will be understood by those of ordinary skill in the art that various substitutions, changes in form and alterations may be made therein without departing from the spirit and the scope of the present invention. Therefore, the scope of the present invention is not limited to the described embodiments, but is limited only by the accompanying claims and equivalents thereof, and any alterations equivalent to the accompanying claims are within the scope of the present invention.

What is claimed is:

1. An aerial survey plane having a cover for protecting a lens of an infrared camera for an aerial survey, the plane comprising:

an aerial survey observation window provided on a bottom surface of a fuselage of an aerial survey plane and having a predetermined size;

an aerial survey infrared camera disposed at the aerial survey observation window and facing a ground surface or a water surface;

at least one shock absorbing part disposed on a lower part of the aerial survey infrared camera to absorb shock applied to the aerial survey infrared camera from the aerial survey plane;

13

at least one support vertically provided on the shock absorbing part to support the aerial survey infrared camera while surrounding the aerial survey infrared camera;

a lifting part to lift up and down the aerial survey infrared camera;

a protective cover provided between the aerial survey infrared camera and the bottom surface of the fuselage of the aerial survey plane and having a size to cover the aerial survey observation window to close the aerial survey observation window before the aerial survey plane starts an aerial survey;

at least one motor disposed on at least one side surface of the protective cover to move the protective cover in a predetermined direction so that the aerial survey observation window is opened to start the aerial survey and the aerial survey observation window is closed to protect the lens of the aerial survey infrared camera; and

a controller to remotely control the opening and the closing of the protective cover.

2. The aerial survey plane according to claim 1, wherein the lifting part is integrally formed with the support and has at least one of a screw type, a hydraulic type and an electronic type.

3. The aerial survey plane according to claim 1, wherein the lifting part is a lever type capable of lifting up or down the aerial survey infrared camera by one manipulation.

4. The aerial survey plane according to claim 1, wherein the protective cover comprises a hard plate.

5. The aerial survey plane according to claim 4, wherein the motor comprises a rotating gear part comprising a protruding part to move the protective cover in one direction, and the protective cover comprises a groove part having a predetermined pitch to engage with the protruding part of the gear unit.

6. The aerial survey plane according to claim 5, wherein the groove part comprises at least one row of grooves formed on an upper part or a lower part of the protective cover.

7. The aerial survey plane according to claim 5, wherein the groove part is formed on at least one of side surfaces of the protective cover.

8. An aerial survey plane having a cover for protecting a lens of an infrared camera for an aerial survey, the plane comprising:

14

an aerial survey observation window provided on a bottom surface of a fuselage of an aerial survey plane and having a predetermined size;

an aerial survey infrared camera disposed at aerial survey observation window and facing a ground surface or a water surface;

guide blocks disposed at a lower part of the aerial survey infrared camera while interposing the aerial survey observation window therebetween and comprising a coupling part on an upper end thereof to be coupled to the aerial survey infrared camera;

a guide groove formed in a longitudinal direction on side surface of the guide blocks facing each other;

a protective cover inserted into the guide groove to move back and fourth in the longitudinal direction;

a wire fixedly installed on at least one of side ends of protective cover;

a first motor and a second motor disposed on both sides of the guide block, respectively, to wind the wire fixedly installed on the side end of the protective cover; and

a controller to remotely control the opening and the closing of the protective cover.

9. The aerial survey plane according to claim 8, wherein an upper part of the guide block is fixed to the aerial survey infrared camera through the coupling part.

10. The aerial survey plane according to claim 8, wherein a lower part of the guide block further comprises a shock absorbing part to absorb a shock applied thereto.

11. The aerial survey plane according to claim 8, wherein the first motor winds the wire while the second motor applies a predetermined amount of tension to the wire fixedly coupled to the protective cover and the second motor to suppress a fluctuation of the protective cover when closing the aerial survey observation window, and the second motor winds the wire while the first motor applies a predetermined amount of tension to the wire fixedly coupled to the protective cover and the first motor to suppress the fluctuation of the protective cover when opening the protective cover.

12. The aerial survey plane according to claim 8, wherein the protective cover is provided between the aerial survey infrared camera and the bottom surface of the fuselage of the aerial survey plane and has a size to cover the aerial survey observation window to close the aerial survey observation window before the aerial plane starts an aerial survey.

\* \* \* \* \*